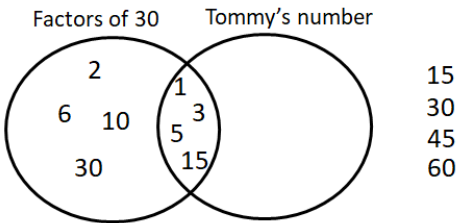

## Year 6 Remote Learning – Week Beginning 12<sup>th</sup> October 2020

Please make sure you are reading every day and practising times tables. You can use TT Rockstars and your log-in details are in your Reading Record. You can record what you are reading in your Reading Record. You can also practise spelling and handwriting using the vocabulary from the Topic timetable below.

### Maths

For short teaching videos relating to each daily topic, please go to <https://resources.whiterosemaths.com/resources/year-6/autumn-block-2-four-operations/> and find the relevant video. We have not included the worksheets that are referred to in the videos, but the questions below relate to the learning in the videos.

Monday	<p><b>Factors and Multiples</b></p> <p>Tommy: I'm thinking of a 2-digit number between 20 and 50</p> <p>Whitney: My number is 30 The common factors of 30 and Tommy's number are 1, 3, 5 and 15</p>  <p>What is Tommy's number?</p> <p>1) Complete the sequence: 7, 14, __, __, 35, 42, __</p> <p>2) Complete the sequence: __, 12, __, 24, 30, __</p> <p>3) Complete the sequence: __, 9, 18, __, 36, __</p> <p>4) Complete the sequence: 4, __, 12, __, 16, __</p> <p>- Find common Factors of 24 and 36 Use a Venn diagram to demonstrate</p>
Tuesday	<p><b>Squares and Cubes</b></p> <p>Dexter works out 20 squared</p> <p>Annie works out 20 cubed</p> <p>Find the difference between Dexter's and Annie's numbers.</p>
Wednesday	<p><b>Arithmetic –paper 9 year 5</b></p>

Thursday

Revise times tables and division facts to help with short and long division next week.

Friday

Shade all the prime numbers to 100.

1	2	3	4	5	6	7	8	9	10
11	12	13	14	15	16	17	18	19	20
21	22	23	24	25	26	27	28	29	30
31	32	33	34	35	36	37	38	39	40
41	42	43	44	45	46	47	48	49	50
51	52	53	54	55	56	57	58	59	60
61	62	63	64	65	66	67	68	69	70
71	72	73	74	75	76	77	78	79	80
81	82	83	84	85	86	87	88	89	90
91	92	93	94	95	96	97	98	99	100

Can you find the nearest prime number before and after each number below?

The first one is done for you.

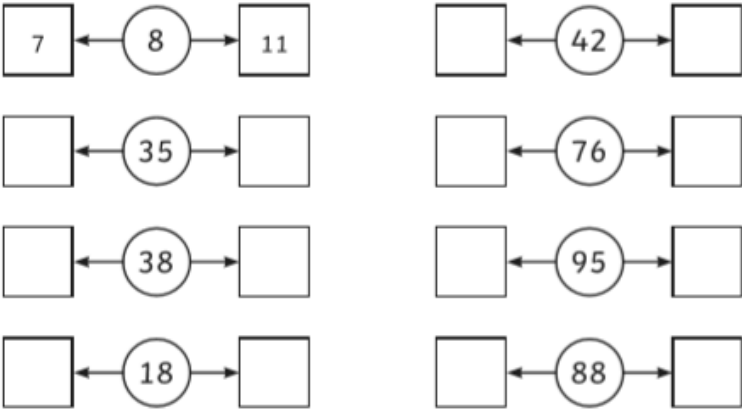

**English**

The focus of this week's English learning is to plan a letter of complaint to the White Star Line. Please use Spelling Frame to help you learn your spellings. If you want to print off the resources. You can just write on paper you have at home or use your Home Learning book.

Monday

Spelling  
Continue to learn words with 'ie' and 'ei' spellings

Reading comprehension – an extract from 'World of Warriors – A New Hero' by Curtis Jobling

The reading comprehension is to help you get better at:

- retrieving information,
- using clues to understand what isn't said or shown
- understanding the author's choice of words

Tuesday

What is an adverb?

Why do we use them in our writing and speech?



Adverbs

<https://www.bbc.co.uk/bitesize/topics/zwwp8mn/articles/zgsgxfr>

**Adverbs**

- Adverbs are used to describe a verb
- Adverbs can be before or after a verb

**Sentences**  
Rewrite your sentences of last week (on adjectives) to include an appropriate adverb.

bird      ball

Mrs Crittenden

desk      lunch



Wednesday

**Plan**

<p><b>Introduction</b> <i>Notes on why you are writing</i></p>	<p><b>Main body</b> <i>Details on what you want to complain about</i></p> <p><i>Impact</i></p>	<p><b>Concluding paragraph</b> <i>Your expectations – what do you want the company to do?</i></p>
--	--	---

Plan a letter of complaint to the White Star Line

Introduction: why you are writing

Main body: include details of what you want to complain about



1. Captain travelling at top speed, encouraged by the Manging Director of White Star Line Mr Bruce Ismay
2. Captain didn't heed the warnings from other ships in the area

Include the impact (effect that had on the ship and people on board and also relatives, friends and family not on board)

Concluding paragraph: any expectations/closing remarks

For example all classes to be allowed on the lifeboats

Thursday	<p>11+  <b>BLACK HISTORY MONTH</b>  <b>Black History Month</b> provides a fantastic opportunity for us to recognize the outstanding contributions people of African and Caribbean descent have.</p> <p>For the rest of this week plan your own person to research and produce a presentation on that person.</p>
Friday	<p><b>BLACK HISTORY MONTH</b>  <b>Black History Month</b> provides a fantastic opportunity for us to recognize the outstanding contributions people of African and Caribbean descent have.</p> <p>For the rest of this week plan your own person to research and produce a presentation on that person.</p>

<u>Topic</u>	
Monday	<p>History</p> <p>Investigate the question:</p> <p>Who is responsible for the sinking of the Titanic?</p>
Tuesday	<p>Science – Spectrum</p> <div style="display: flex; justify-content: space-around;"> <div data-bbox="371 992 909 1380"> <p style="text-align: center;"><b>Isaac Newton</b></p>  <p>Isaac Newton was an English scientist and mathematician. His ideas and discoveries are still considered to be important today.</p> </div> <div data-bbox="922 992 1505 1380"> <p style="text-align: center;"><b>Isaac Newton</b></p>  <p>In 1666, Newton made a discovery about light that led him to develop his Theory of Colour, a theory that still informs our understanding of light today.</p> <p>He placed a prism in front of ray of light, and his observations were incredible.</p> </div> <div data-bbox="1518 992 2078 1380"> <p style="text-align: center;"><b>Prisms</b></p> <p>A prism is a solid shape whose 2 ends are the same size and shape.</p> <p>Isaac Newton used a transparent triangular prism in his investigation.</p> <p>What can you remember about what happens to light when it travels between air and a transparent material?</p>  </div> </div>

Wednesday	Geography - Find the six figure grid reference for Kent and London.
Thursday	Music - Evelyn Glennie played a vibraphone. Conduct some research to answer these questions: What is it? How does it produce sound? Why does it move?
Friday	RE- What is humanism? What do humanists believe?